

Project _____

Item Number _____

Quantity _____

SL160/SL200/SL280



SL160 / SL200 / SL280 SILVERLINE Spiral Mixers

Models:

- SL160: 210 quart (230 Liter) Spiral Mixer
- SL200: 265 quart (290 Liter) Spiral Mixer
- SL280: 370 quart (400 Liter) Spiral Mixer

Features:

- Stainless steel bowl, spiral dough hook, and shaft
- Separate bowl and agitator motors
- Has two speeds and reverse function
- Control board has separate timers for 1st and 2nd speed
- Mixer is equipped with built in castors and leveling feet for easy positioning and set-up
- Safety switches protect operator from injury if bowl lid is open
- Powerful belt drive provides low vibration, low noise, and economical maintenance for years of reliable service



Spiral Mixer

Dough Capacity:

SL160: 353lb (160kg)
SL200: 441lb (200kg)
SL280: 617lb (280kg)

Dough hook:

1st speed: 95 rpm
2nd speed: 190 rpm

Bowl:

20 rpm

Univex Corporation

Standard Accessories:

- Stainless steel bowl
- Stainless steel dough hook

Warranty:

- One year, on-site parts and labor



WE RAISE THE BAR. WE SET THE STANDARD.

SILVERLINE Spiral Mixer

SL160 / SL200 / SL280

Line drawing is the SL280

	SL160	SL200	SL280
A	36 3/4" (93.2cm)	38" (96.3cm)	43" (109.1cm)
B	32 1/2" (82.5cm)	32 1/2" (82.5cm)	32 1/2" (82.5cm)
C	59 1/8" (150.1cm)	59 1/8" (150.1cm)	58 3/8" (148cm)

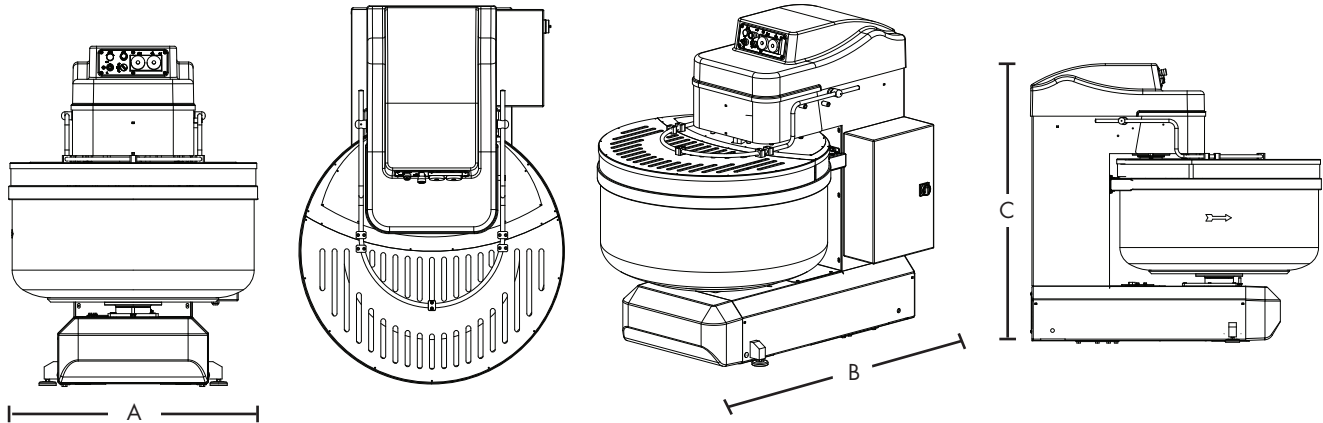

Electrical Information								
Model	Voltage	Phase	Spiral hp(kW)	Bowl hp(kW)	Total hp(kW)	Spiral Amps	Bowl Amps	Total Amps
SL160	220	3	15 (11)	1 (.75)	16 (11.75)	52.5	3.6	56.98
SL160 Optional Voltage	400	3	15 (11)	1 (.75)	16 (11.75)	26.25	1.8	28
SL200	220	3	15 (11)	1 (.75)	16 (11.75)	52.5	3.6	56.98
SL200 Optional Voltage	400	3	15 (11)	1 (.75)	16 (11.75)	26.25	1.8	28
SL280	220	3	15 (11)	1 (.75)	16 (11.75)	52.5	3.6	56.98
SL280 Optional Voltage	400	3	15 (11)	1 (.75)	16 (11.75)	26.25	1.8	28

Plug Info:
Hard Wire With Shutoff

Transmission: Heavy duty low noise and low vibration belt drive.

Bowl Guard: Swings open for full access to bowl. Guard must be closed for mixer operation.

Controls: Control panel with digital timers. Separate timers for high and low speed. Security key for manual use. Bowl reverse direction switch.

Shipping Information			
Model	Net Weight	Shipping Weight	Overall Dimensions
SL160	1,521 lbs. (690Kg)	1,631 lbs. (740Kg)	69" (176cm) H x 41" (105cm) W x 63" (160cm) D
SL200	1,653 lbs. (750Kg)	1,764 lbs. (800Kg)	69" (176cm) H x 51" (130cm) W x 79" (200cm) D
SL280	1,830 lbs. (830Kg)	1,940 lbs. (880Kg)	69" (176cm) H x 55" (140cm) W x 87" (220cm) D

*The weight and dimensions of the pallet are included in the weight and dimensions above.



Univex Corporation
www.Univexcorp.com

3 Old Rockingham Rd
Salem, NH 03079
United States of America

INTL TEL: (800)258-6358
TEL: (603)893-6191
INTL FAX: (800)356-5614
FAX: (603)893-1249