

Project

Quantity

Item #

Model Specified:

CSI Section 11400

### G-Series Three Section 115V Storage Freezers/Self-Contained



Equipped with an easy to use microprocessor control!



Model G31010



Traulsen's G-Series product line also includes three section reach-in storage freezer models designed to operate at 115V. These models are available with either full or half length doors and offer the convenience of a variety of different door hingings to choose from. Built with durable exteriors, reliable controls, balanced, efficient refrigeration systems and a variety of user-friendly features, these products are the right fit for nearly any application. They are designed and built to the highest standards, and epitomize the quality design and construction Traulsen is known for.

#### AVAILABLE MODELS

Model #	Door	Hinging
G31000	Half	Left-Right-Right
G31001	Half	Left-Left-Right
G31002	Half	Right-Right-Right
G31003	Half	Left-Left-Left
G31010	Full	Left-Right-Right
G31011	Full	Left-Left-Right
G31012	Full	Right-Right-Right
G31013	Full	Left-Left-Left

### Standard Product Features

- High Quality Stainless Steel Exterior Front and Doors
- Corrosion Resistant Anodized Aluminum One-Piece Sides
- Durable Anodized Aluminum Interior
- Microprocessor Control With LED Temperature Readout
- Top-Mounted, Balanced, Self-Contained Refrigeration System
- Large High Humidity Evaporator Coil Outside The Food Zone
- Load-Sure Guard Protects Against Improper Loading
- Full or Half Length Stainless Steel Doors With Locks
- Self-Closing Doors With Stay Open Feature At 120 Degrees
- Guaranteed For Life Cam-Lift Hinges
- Guaranteed For Life Horizontal Work Flow Door Handle
- Automatically Activated LED Lights
- Damage Resistant Stainless Steel Breaker Caps
- Three (3) Adjustable Epoxy Coated Shelves Per Section, Supported On Shelf Pins (installed at the factory)
- Energy Saving Automatic Non-Electric Condensate Evaporator
- Magnetic Snap-In EZ-Clean Door Gaskets
- Gasket-Protecting Anodized Aluminum Door Liner
- Anti-Condensate Door Perimeter Heaters
- Thermostatic Expansion Valve Metering Device Provides Quick Refrigeration Recovery Times
- Stainless Steel One-Piece Louver Assembly
- 9' Cord & Plug Attached
- Set of Four (4) 6" High Casters With Locks
- Three Year Parts And Labor Warranty
- Five Year Compressor Warranty

### Optional Accessory Kits

- Additional Epoxy Coated Shelves\*
- No. 1 Type Tray Slides\* To Accommodate either: (1) 18" x 26" or (2) 14" x 18" Sheet Pans, Adjustable To 2" O.C.
- No. 4 Type Tray Slides\* To Accommodate (1) 18" x 26" Sheet Pans (equips one full section)
- Universal Type Tray Slides\* To Accommodate Either (1) 18" x 26" or (2) 14" x 18" Sheet Pans, or (2) 12" x 20" Steam Table Pans, Adjustable To 4" O.C.
- Plated Shelves\* (for use in lieu of standard shelving)
- EZ-Change Interiors (#1, universals, universal heavy duty tray slides and shelves)
- 6" High Adjustable Legs (for use in lieu of standard casters)

\*Please refer to spec sheet TR35872 for optional accessory kit details.  
All optional accessory kits are shipped separately for later installation by others at the jobsite.



Listed by Underwriters Laboratories Inc., to U.S. and Canadian safety standards and Listed by NSF International.



Approval: \_\_\_\_\_



TRAUlsen  
4401 BLUE MOUND RD.  
PHONE 1 (800) 825-8220  
Website: www.traulsen.com

FT. WORTH, TX 76106  
FAX-MKTG. 1 (817) 624-4302

Project	Quantity	Item #
Model Specified:		CSI Section 11400

## Specifications

### Construction, Hardware and Insulation

Cabinet exterior front, louver assembly and doors are constructed of 20 gauge stainless steel. Cabinet sides (including returns), interior and door liners are constructed of anodized aluminum. The exterior cabinet top, back and bottom are constructed of heavy gauge aluminized steel. A set of four (4) 6" high casters are included.

Doors are equipped with a gasket protecting metal door pan, removable plug cylinder locks and guaranteed for life cam-lift, gravity action, self-closing metal, glide hinges with stay open feature at 120 degrees. Hinges include a concealed switch to automatically activate the interior LED lighting. Guaranteed for life, work flow door handles are mounted horizontally over recess in door which limits protrusion from door face into aiseways.

Gasket profile and Santoprene® material simplify cleaning and increase overall gasket life. Anti condensate heaters are located behind each door opening.

Both the cabinet and door(s) are insulated with an average of 2" thick high density, non-CFC, foamed in place polyurethane.

DIMENSIONAL DATA	
Net Capacity cu. ft.	69.0 (1954 cu l)
Length Overall in.	76 <sup>5</sup> / <sub>16</sub> (193.8 cm)
Depth - Over Body in.	32 (81.3 cm)
Depth - W/Door Open 90° in.	56 <sup>7</sup> / <sub>8</sub> (144.5 cm)
Depth - Overall in.	35 (88.8 cm)
Clear Door Width in.	21 <sup>1</sup> / <sub>8</sub> (53.6 cm)
Clear Half Door Height in.	27 <sup>1</sup> / <sub>2</sub> (69.9 cm)
Clear Full Door Height in.	57 <sup>7</sup> / <sub>8</sub> (146.3 cm)
Number of shelves	9
Shelf area sq. ft. <sup>1</sup>	51.9 (4.82 sq m)
Height - Overall in.	83 <sup>1</sup> / <sub>4</sub> (211.5 cm)
ELECTRICAL DATA	
Voltage	115/60/1
Feed Wires with Ground	3
Full Load Amperes	15.8
REFRIGERATION DATA	
Refrigerant	R-404A
BTU/HR - HP <sup>2</sup>	4690 (¾ HP)
CARTON DIMENSIONS Domestic Crated Only	
Length - Crated in.	91 (231 cm)
Depth - Crated in.	43 (109.2 cm)
Height - Crated in.	83 <sup>1</sup> / <sub>2</sub> (212.1 cm)
Volume - Crated cu. ft.	189 (5354 cu l)
WEIGHT DATA	
Net Weight - Uncrated lbs.	690 (313 kg)
Gross Weight - Crated lbs.	870 (395 kg)

### NOTES

- NOTE: Figures in parentheses reflect metric equivalents.
- Figure shown reflects the area of standard shelf compliment plus the additional storage area available on the cabinet bottom.
  - Based on a 90 degree F ambient and -20 degree F evaporator. For remote data please refer to spec sheet form TR35837.
  - 12" Top clearance preferred for optimum performance and service access.

### Refrigeration System

A top mounted, self-contained, balanced refrigeration system using R-404A refrigerant is conveniently located behind the one piece louver assembly. It features an easy to clean front facing condenser, thermostatic expansion valve, air-cooled, semi-hermetic compressor, large, high humidity evaporator coil located outside the food zone and a top mounted non-electric condensate evaporator. A 9' cord and plug is provided. Standard operating temperature is 0 to -5°F.

### Controller

The easy to use water resistant microprocessor control system is supplied standard. It includes a 3-Digit LED Display, and a Fahrenheit or Celsius Temperature Scale Display Capability.

### Interior

Standard interior arrangements include three (3) epoxy coated wire shelves per section, mounted on shelf pins, installed at the factory. Shelves are full-width, and do not have any large gaps between them requiring the use of "bridge" or "junior shelves." Recommended load limit per shelf should not exceed 225 lbs.

### Warranties

Both a three year parts and labor warranty and a five year compressor warranty (self-contained models only) are provided standard.

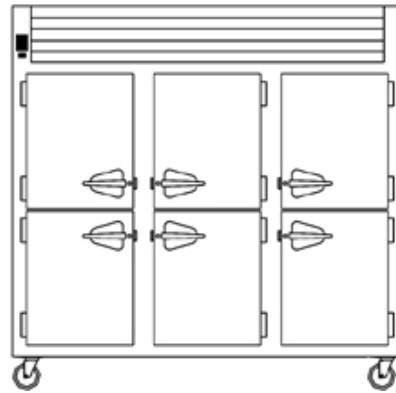

Elevation View

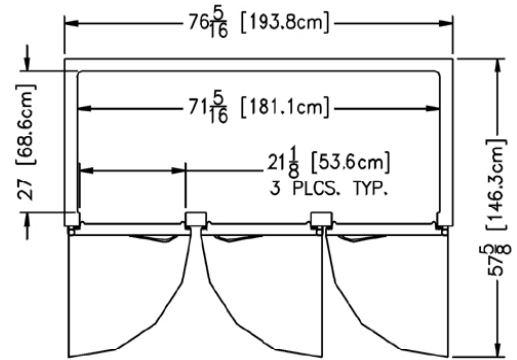

Plan View

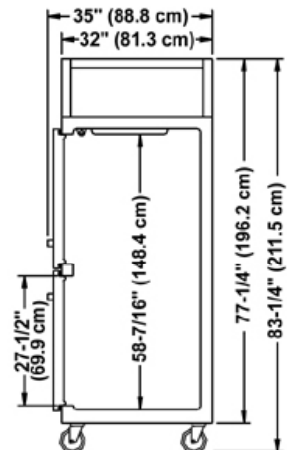
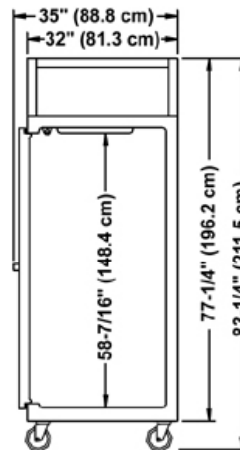

Section View - All Models



Equipped with one NEMA 5-20P Plug

Continued product development may necessitate specification changes without notice.  
Part No. TR35849 (REV. 07-01-16)

TRAUlsen  
4401 BLUE MOUND RD.  
PHONE 1 (800) 825-8220  
Website: www.traulsen.com

FT. WORTH, TX 76106  
FAX-MKTG. 1 (817) 624-4302

**Traulsen**