



VOAM48-79

VOAM-79 SERIES

Vertical Open Air Merchandisers 79" Height

**MEETS
2017 DEPT. OF
ENERGY
STANDARDS**

MODELS

- VOAM36-79
- VOAM48-79
- VOAM60-79
- VOAM72-79

FEATURES

CONSTRUCTION

- Contemporary styling provides an attractive product showcase
- Standard electronic controller with these features:
 - Ability to monitor defrost functions from the front panel interface
 - Audible and visual alarm
 - Eliminates room thermostat, defrost termination/fan delay control, defrost timer and digital thermometer or other temperature indicator
- Standard LED lighting in canopy
- 24 gauge painted textured galvanized steel exterior and interior
- Standard retractable vinyl night curtain
- Stainless steel floor pans (removable for easy service)
- 2" foamed-in-place "zero ODP" urethane insulation

- Automatic defrost
- Easily accessible electrical enclosure
- Shelves adjustable in 1" increments
- Four tiers of two-position shelving with price tag molding
- Perforated interior back wall for better air flow

REFRIGERATION

- Refrigerant: R-404A
- Front air intake and rear air discharge
- Self-contained, bottom mount refrigeration system
- Condensing unit slides out front of case for easy cleaning and servicing
- Temp. range: 34° to 41°F (1° to 5°C)
- R-factor (insulation efficiency rating): 17.24
- Standard energy efficient automatic condensate removal system

WARRANTY

- **Standard limited three year parts and labor**
- **Additional two year coverage on compressor part**

OPTIONS

- Add suffix "R" for remote refrigeration system
- Stainless steel interior and exterior (ends, base and bumper remain black)
- LED shelf light kit
- Custom exterior colors (ends, base and bumper remain black)
- Casters
- Security cover
- Product hooks
- Condensate pump
- Higher capacity condensate evaporator pan (depending on model)

BID SPECIFICATIONS

Item no. VOAM_____-79
 Provide_____() Vertical Open Air Merchandiser(s), Master-Bilt® model no. VOAM_____-79.

Merchandiser constructed of 24 ga. painted textured galvanized steel interior and exterior & will be equipped with an elec-

tronically controlled monitoring system.

Other features include retractable vinyl night curtain, adjustable two-position shelves, automatic defrost and 2" thick "zero ODP" polyurethane insulation.

Refrigeration system to be self-contained, have a front condenser air intake and rear air

discharge and use R-404A refrigerant. Temperature range will be 34° to 41°F (1° to 5°C).

Merchandiser to have standard limited three year parts and labor warranty with additional two year coverage on compressor part.

Merchandiser to be UL & C-UL listed and UL-EPH classified.



VOAM-79 SERIES

VERTICAL OPEN AIR MERCHANDISERS – 79" HEIGHT

TECHNICAL SPECIFICATIONS

MODEL	DIMENSIONS (in.)			DIMENSIONS (mm)			VOLTS	AMPS**	UNIT H.P.	NO. OF SHELVES	STANDARD SHELF WIDTH (in inches)	CAP. CU. FT.	SHIP WT. LB/KG
	L	D	H	L	D	H							
VOAM36-79	35 1/2	34	79	902	864	2007	115	11.5	3/4	4	32 1/2	20.8	550/250
VOAM48-79	47 1/2	34	79	1207	864	2007	115	14.5	1	4	44 1/2	28.3	675/307
VOAM60-79	59 1/2	34	79	1511	864	2007	208-230*	7.8	1	8	28	35.9	800/364
VOAM72-79	71 1/2	34	79	1816	864	2007	208-230*	7.8	1	8	34	43.4	925/420

***Note: 208-230/60/1 also requires neutral and safety ground wire. **Factory installed condensate evaporator pan requires a dedicated 15 amp, 120 volt circuit.**

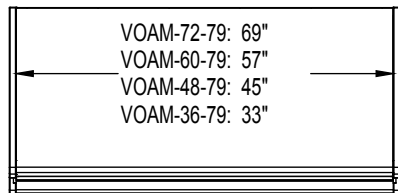

PLAN VIEW

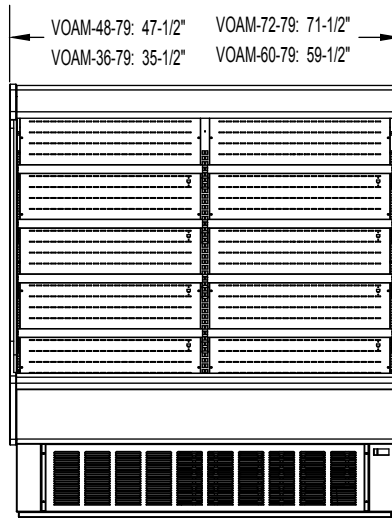

ELEVATION VIEW

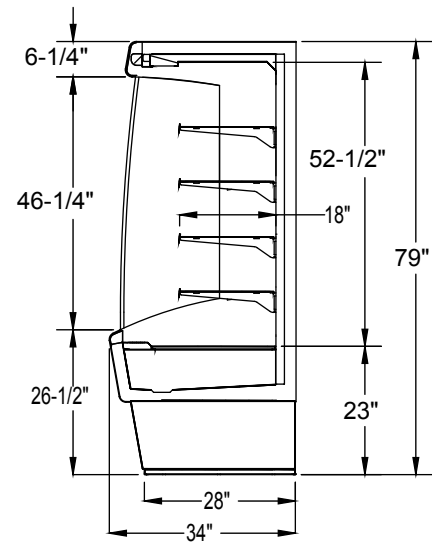

SIDE VIEW

LISTINGS



HOOKUP

VOAM36-79 and VOAM48-79 via plug in, 9 foot long, flexible 3 wire 14/3 cord with molded plug.

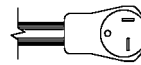

NEMA 5-20P (VOAM36-79 & VOAM48-79) - APPLIES TO U.S. MODELS ONLY, CANADIAN MODELS WILL NEED TO BE HARDWIRED.

VOAM60-79 & VOAM72-79: via plug in, 9 foot long flexible four wire 208-230v 14/4 cord with neutral and ground wires and molded plug.

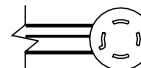

NEMA L14-20P (VOAM60-79 & VOAM72-79)

Condensate evaporator pan via plug in, 10 ft. long with molded plug.



NEMA 5-15P (Condensate evaporator pan)

RECOMMENDED OPERATING CONDITIONS

- Merchandisers designed to hold product in the 34° to 41°F (1° to 5°C) range
- Designed to operate in air-conditioned stores where the maximum temperature is 75°F and the maximum relative humidity is 55%
- Should not be installed in direct sunlight
- Should not be installed near HVAC vents, fans or doorways that will disrupt airflow and compromise the function of the air screen inside the case
- Bottom shelf should not be loaded such that the front air intake is obstructed
- Floor drain should be properly trapped
- Factory installed controls should not be altered, removed or replaced without consent of the factory
- Product must not be displayed in the cold air curtain



908 Highway 15 North • New Albany, MS 38652
 PHONE: 800-647-1284 or 662-534-9061 • FAX: 800-232-3966 or 662-534-6049 • www.master-bilt.com

All specifications subject to change without notice.